

## SL Series

High-Pressure Washdown Linear LED Tube

Project \_\_\_\_\_

Date \_\_\_\_\_ Type \_\_\_\_\_

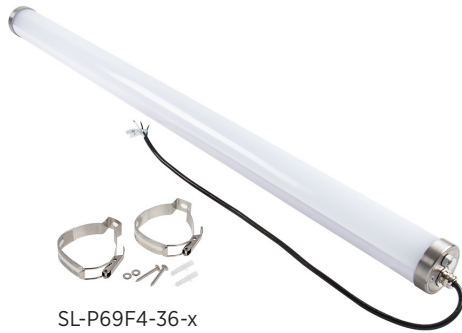

### Description

SL series LED washdown tube fixtures meet NSF Std. 2 and FDA/USDA criteria making them ideal for food and beverage processing and other sanitary environments. Smooth tubular design and gasketed stainless steel end caps are easy to clean and prevent the collection of dust, residue, and contaminants. The luminaire is IP69K rated—built to withstand up to 1,200 PSI high-pressure cleaning and usable in wet locations such as car washes and industrial kitchens.

### Optics

- IK10 impact resistant extruded polycarbonate design
- UV-resistant 3" diameter cylindrical lens reduces contaminant buildup
- Low-glare frosted lens with wide 120° beam provides uniform illumination

### Mechanical

- IP69K highest enclosure rating designed for high pressure, high temperature hose-down applications
- Stainless steel, corrosion-resistant end caps are sealed with heavy-duty silicone gasket
- Surface-mount stainless steel tension clamps included
- Optional stainless steel aircraft cable hanging kit

### Electrical

- 100–277 VAC input voltage range
- 2 ft power cord with liquid-tight power entry
- ≥0.9 power factor
- Premium performance of 140 lm/W
- Available in 4000K and 5000K at 80+ CRI
- Single- or dual-end wiring versions available for easy linking
- 75,000 hour (L70) rated life

### Available Models<sup>1</sup>

#### Single End

- SL-P69F4-36-W
- SL-P69F4-36-P

#### Dual End

- SL-P69F4-36-W (D)
- SL-P69F4-36-P (D)

### Part Number Breakdown

Example: SL-P69F4-36-P

Family	Construction	Length	Wattage	CCT
SL	P69F [IP69K, frosted PC lens]	4 [4 ft]	36 [36 W]	W [4000K]
				P [5000K]



### Optional Accessories

#### Suspension Kit

- TPLF-HKO



### Application

IP69K rating and NSF compliant design makes these lights ideal for food processing facilities, canning/bottling plants, brewery and distillery operations, agriculture and farming applications, cold storage, commercial and institutional kitchens, packaging plants, inspection facilities, treatment plants, cleanrooms, car washes, and other areas where a waterproof, sanitation compliant lighting solution is required.

### Warranty

Five (5) Year Warranty

### Certifications and Compliances

SL series lights are UL Listed in compliance with UL 1598 (IFAM) and are IP69K rated for installation in wet locations. These are listed as DLC Premium. They are also NSF listed in compliance with NSF Std. 2.



T 314.743.3067  
 F 314.972.6202  
 email: commercial-sales@superbrightleds.com  
 www.superbrightleds.com/cat/industrial-led-lighting/

<sup>1</sup>Contact customer service if interested in options other than those listed.

**SL Series**

High-Pressure Washdown Linear LED Tube

**Dimensional Drawing**

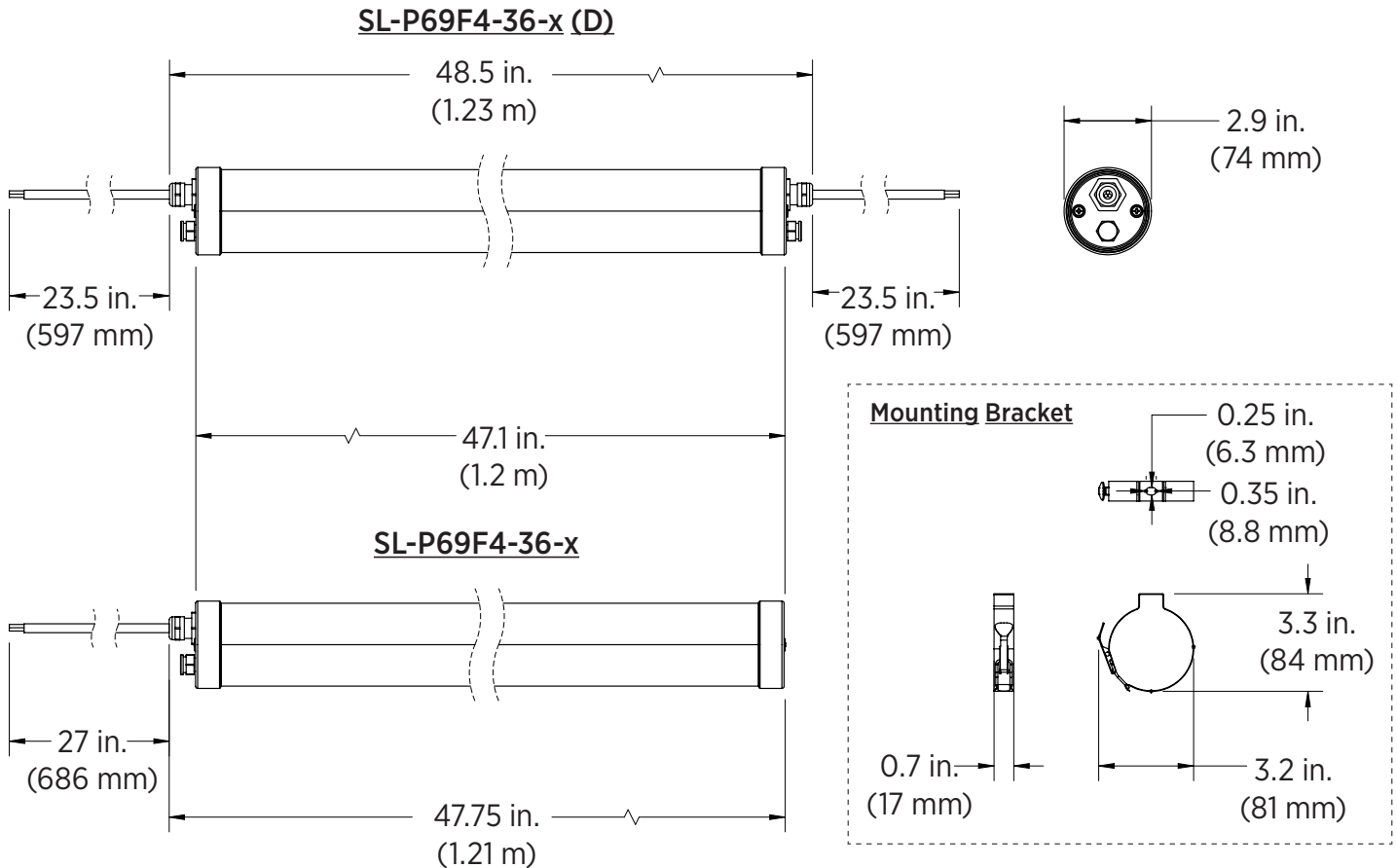

**Specifications**

Model	SL-P69F4-36-W / SL-P69F4-36-W (D)	SL-P69F4-36-P / SL-P69F4-36-P (D)
Intensity	5,040 lm	
Efficacy	≥140 lm/W	
Color Temperature	4000K	5000K
Operating Voltage	100-277 VAC	
Power Consumption	36 W	
Current Draw	300 mA @120 VAC / 130 mA @277 VAC	
Beam Angle	120°	
CRI	80+	
IP Rating	IP69K	
Ambient Operating Temperature	-4°-104° F (-20°-40° C)	
Product Weight	4.1 lb (1.86 kg) / 4.4 lb (2 kg)	4.1 lb (1.86 kg) / 4.4 lb (2 kg)
Rated Life (L70)	75,000 hours	

