

*Important: Read all instructions prior to installation.*

# Easy Dimmer series Multi Zone RGB LED Dimmer Switch for Easy Dimmer Receiver



**Features**

- 3 zones
- Sensitive Glass Touch Panel
- Color Temp Adjustment
- 10 Color Changing Modes
- Mounts in Standard Switch Box



**Parameter**

| Part No.        | Operation Voltage | Dimensions     | Frequency     |
|-----------------|-------------------|----------------|---------------|
| MZ3RF-RGBW5-WMT | 12-24VDC          | 120x75.12x30.7 | 434MHz/868MHz |

**Installation**

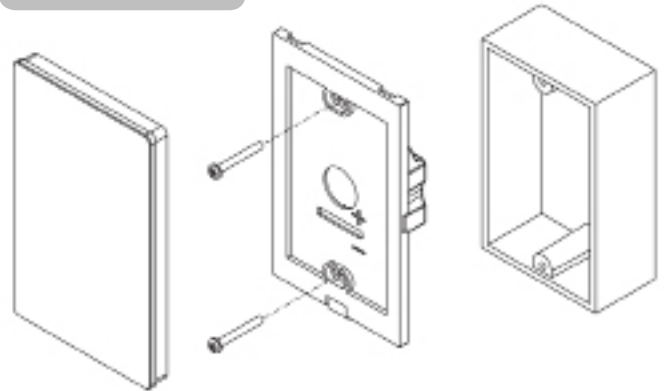

**Product Size**

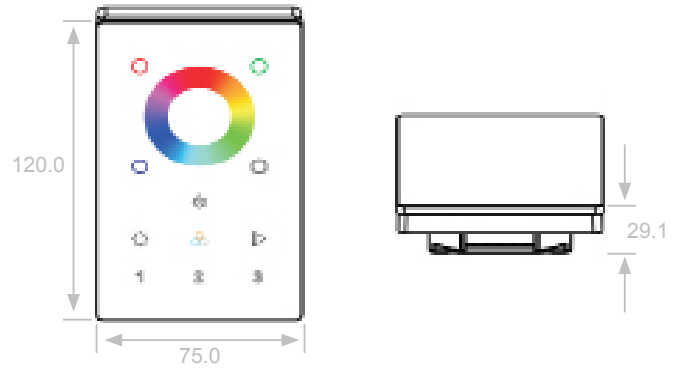

**Wiring Diagram**

**1. Power Transmitter (Remote)**

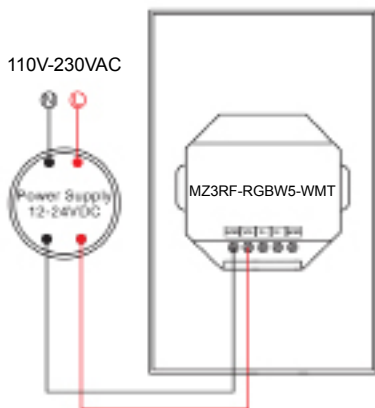

**2. Power Receivers**

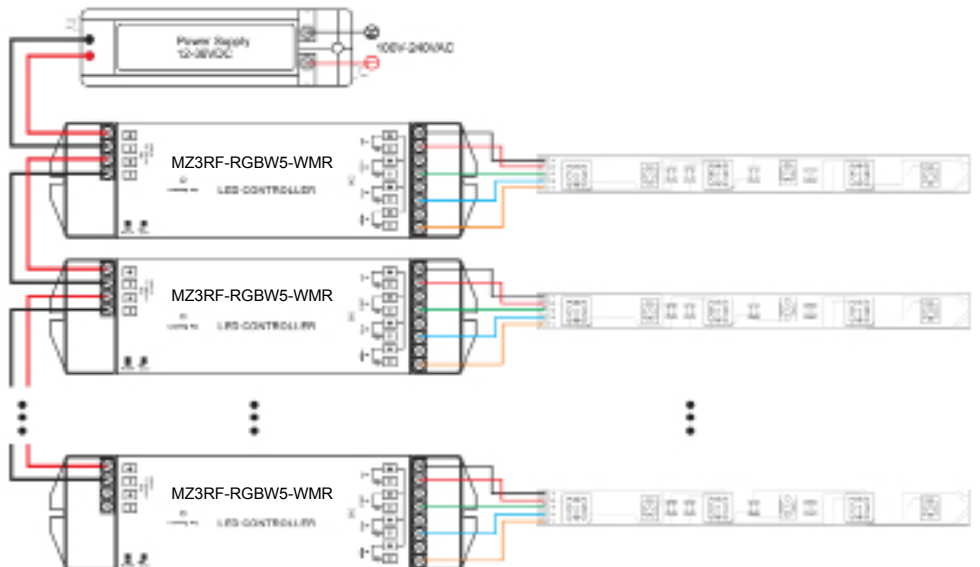

## Button introduction

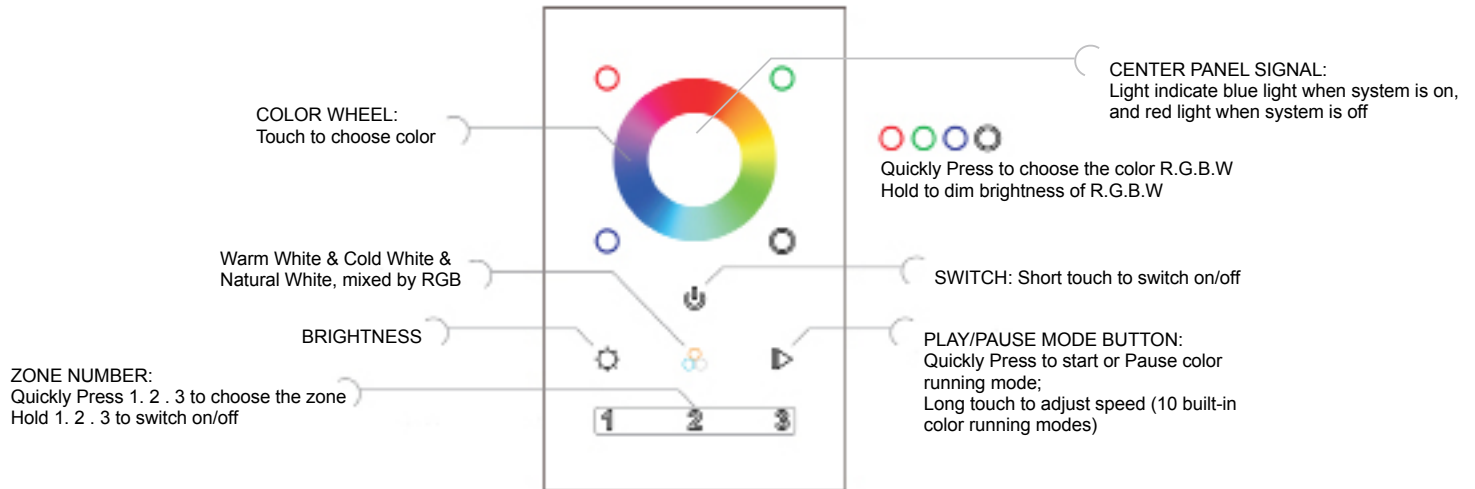

## Programming

### How to Sync to Zones:

Press "Learning Key" on receiver and within 3 seconds, choose one of the numbered zone buttons, depressing the button until the light begins flashing. Light will flash white 2 times, indicating that the light is now linked to that numbered zone and can be controlled via the remote.

## Warranty Agreement

1. We provide lifelong technical assistance with this product:
  - A 3-year warranty is given from the date of purchase. The warranty is for free repair or replacement and covers manufacturing faults only.
2. Warranty exclusions:
  - Any man-made damages caused from improper operation, or connecting to excess voltage and overloading.
  - The product appears to have excessive physical damage.
  - Damage due to natural disasters and accidents.
3. Repair or replacement as provided under this warranty is the exclusive remedy to the customer. We shall not be liable for any incidental or consequential damages for breach of any stipulation in this warranty.
4. Any amendment or adjustment to this warranty must be approved in writing by our company only.

## Safety & Warnings

1. The product shall be installed and serviced by a qualified person.
2. This product is non-waterproof. Please avoid the sun and rain. When installed outdoors please ensure it is mounted in a water-proof enclosure.
3. Good heat dissipation will prolong the working life of the controller. Please ensure good ventilation.
4. Please check if the output voltage of any LED power supplies used complies with the working voltage of the product.
5. Please ensure that adequate sized cable is used from the controller to the LED lights to carry the current. Please also ensure that the cable is secured tightly to the connector to avoid accidents due to overheat and poor contact on the wire.
6. Ensure all wire connections and polarities are correct before applying power to avoid any damages to the LED lights.
7. If a fault occurs please return the product to your supplier. Do not attempt to fix this product by yourself.



4400 Earth City Expy, St. Louis MO 63045



866-590-3533



support@superbrightleds.com