

Important: Read all instructions prior to installation.

200W LED Shoebox Area and Parking Lot Light

Dimensional Drawing

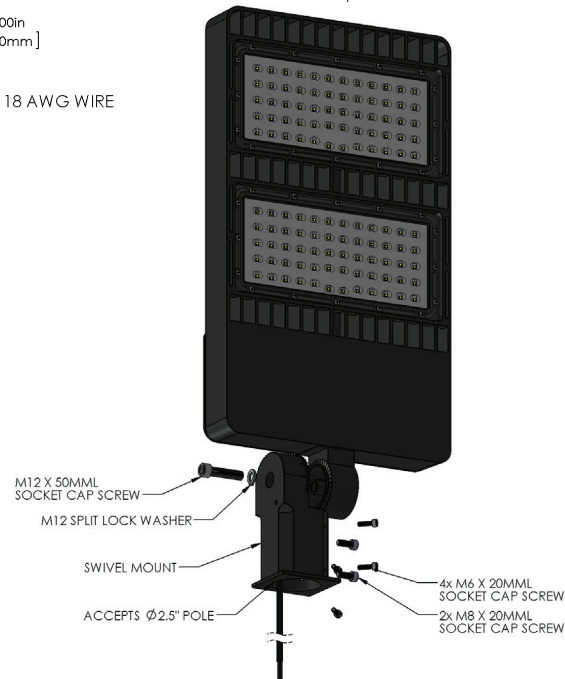
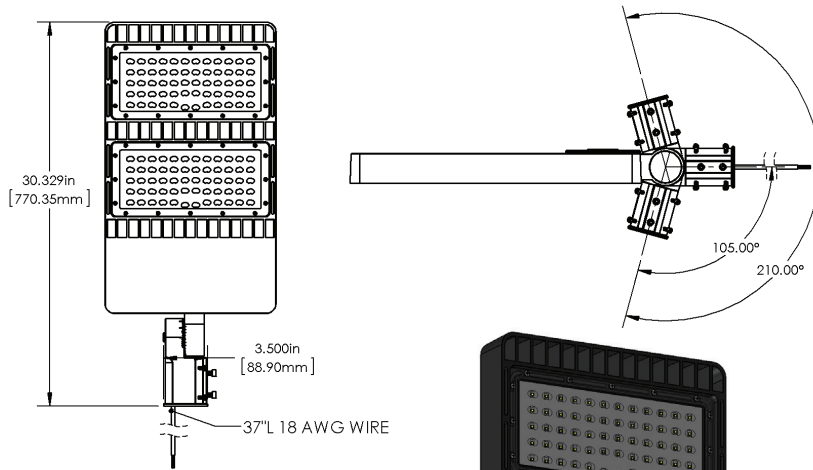
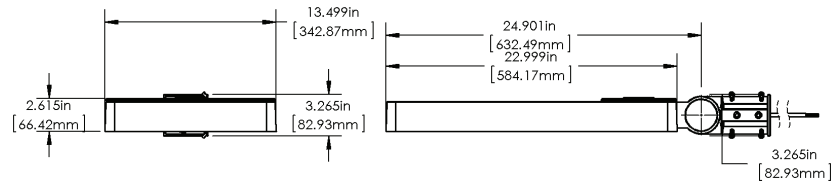

LED Shoebox Area and Parking Lot Light

APL-x200

Installation Manual



Important: Read all instructions prior to installation.

200W LED Shoebox Area and Parking Lot Light

Included Parts

- 1 - 200 Watt Area and Parking Lot Light (APL-x200)
- 1 - Instructional Sheet
- 1 - Slip Fit Bracket
- 1 - Hardware

Optional Accessories

- Square Mount Fixed Arm Kit (APL-FALS)
- Round Mount Fixed Arm Kit (APL-FALR)

Specifications

APL-x200	
Intensity	20000 lm
Replacement For	600 Watt HID
Total Power Consumption	205 Watts
Operating Voltage Range	100~277 VAC
Beam Angle	135 x 85degree
LED Type	Samsung 3535 SMD
Dimensions	13.5in W x 23in L x 2.6in H (34.3cm x 58.4cm x 6.6cm)
Color Temperature (NW,WW)	5000 K / 3000 K
CRI	73
Operating Temperature	-49~113°F (-45~45 °C)
IP Rating	Weatherproof IP65
LED Lifetime	50,000 Hours
Fixture Weight	24 lbs 5.6 oz (11.04Kg)
Standards and Certifications	ETL / RoHS / DLC
Warranty	5 Years

Installation Instructions

1. Remove power prior to installation.
2. Choose mounting method and preassemble light to mounting bracket.
3. Secure fixture with mounting bracket to mounting surface.
4. Connect wiring to power supply. Black to Line, White to Neutral, and Green to Ground.
5. Restore power to circuit to test function then aim fixture.

Installation Instructions

STEP 1

- 1.1- REMOVE SIX SCREWS AND DRIVER COVER

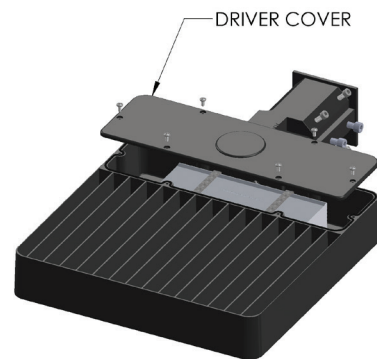

STEP 2

- 2.1- REMOVE THE DRIVER CLAMPS AND DRIVER (DO NOT DISCONNECT ELECTRICAL CONNECTIONS)

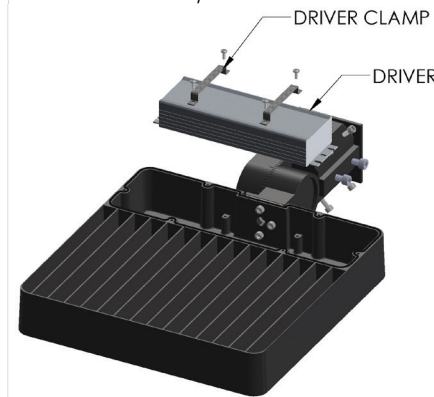

STEP 3

- 3.1- REMOVE LARGE CAP SCREW AND SWIVEL MOUNT
3.2- REMOVE THE M6 SOCKET CAP SCREWS, MOUNT, AND GASKET

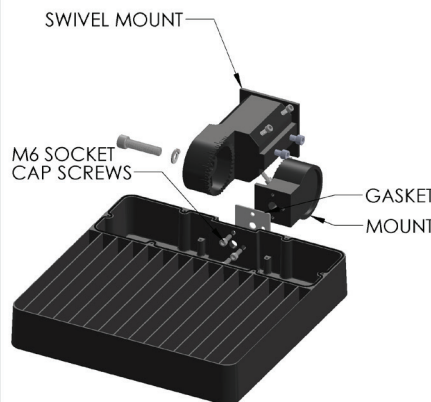

STEP 4

- 4.1- ATTACH NEW APL-FALR OR APL-FALS MOUNT, GASKET, AND SECURE WITH PROVIDED M6 SOCKET CAP SCREWS.
4.2- REATTACH THE DRIVER WITH DRIVER CLAMPS IN STEP 2
4.3- REATTACH THE COVER IN STEP 1

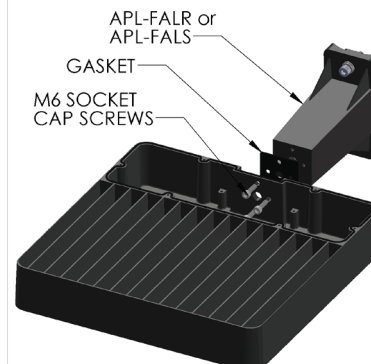

Wiring Diagram

